

## Extended area miniature thin film four channel pyroelectric sensor

### Introduction

A new generation of four channel (quad) Pyreos infrared detectors using a TO-39 package incorporates significantly larger pyroelectric elements achieving almost five times greater energy capture when compared to the existing product series. A combination of the larger pixels and their compact arrangement within a TO-39 package allows better concentration of infrared energy. This enables more efficient optical system design than that required by competing products which use larger packages and elements. The overall result is excellent signal-to-noise ratio (SNR) in NDIR multi-gas measurements.

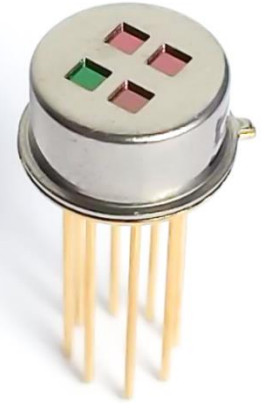

The proven performance of the Pyreos single and dual channel TO-39 range is duplicated in the four channel configuration by utilising the same MEMS sensing element. The excellent thermal and mechanical stability, instant start-up, and fast response enabling pulse rates in excess of 100 Hz are all maintained in the new device.

The sensor has current mode (CM) readout with internal CMOS trans-impedance amplifiers, 10 G $\Omega$  feedback resistors, with voltage output signals centred around half the supply rail. A complete range of IR filters covering the full mid-IR spectrum is available.

#### Sensor Characteristics

Filter aperture	4x 1.5 mm x 1.5 mm
Element size	1.0 mm x 1.0 mm
Package	TO-39
Responsivity <sup>1</sup>	200,000 V/W
D* <sup>1</sup>	2.35 x 10 <sup>8</sup> cm $\sqrt{\text{Hz}}$ /W
Noise <sup>1</sup>	85 $\mu\text{V}/\sqrt{\text{Hz}}$
Op amp with 10 G $\Omega$ feedback resistor	

<sup>1</sup>10 Hz, 500 K, room temperature, without window and optics

<sup>2</sup>With reference to GND

<sup>3</sup>Absolute maximum operating voltage 6.0V

#### Electrical Characteristics

Supply Voltage ( $V_{\text{Supply}}$ )	2.7 to 5.5 V <sup>2 3</sup>
Max. Current Cons.	1.5 mA
Offset Voltage	( $V_{\text{Supply}} / 2$ ) <sup>2</sup>
Microphonics	$S_{\text{vib}} \sim 1 \mu\text{V}/\text{g}$ at 10Hz
Time Constant	$\sim 10$ ms
Operating Temperature	-40 to +85 °C
Storage Temperature	-40 to +110 °C
Offset V max	(+V) – 0.1 V <sup>2</sup>
Offset V min	0.1 V <sup>2</sup>

**Package Information**

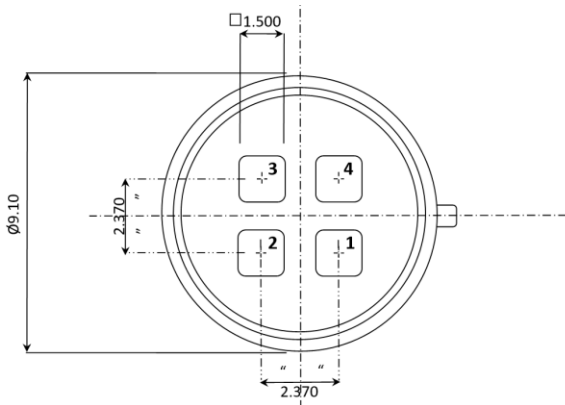

Top View

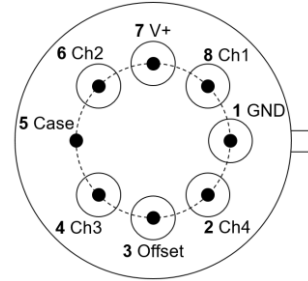

Bottom View

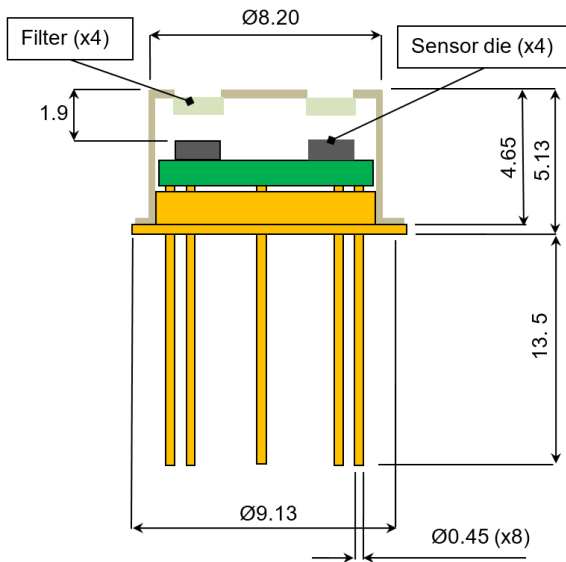

Package dimensions

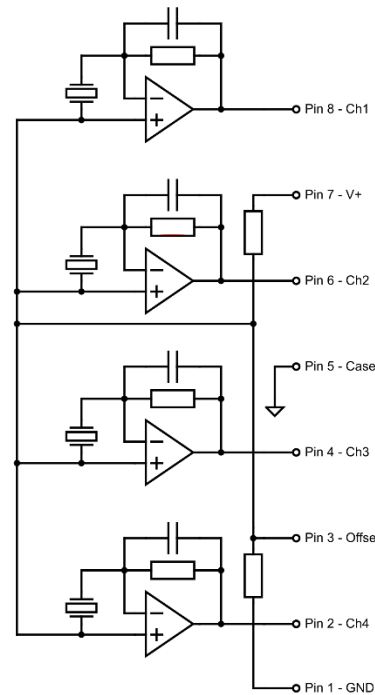

Internal Schematic

Note: Ensure that the sensor base is not in contact with the PCB in order to avoid shorts.

**Order Information**

Please quote PY-ITV-QUAD-TO39(7+1) and your desired filter combination or quote specific part number as per filter table. Contact: [sales@pyreos.com](mailto:sales@pyreos.com)

Search terms: current mode, voltage mode, infrared detector, infrared sensor, MIR, mid-IR, thermopile, photodiode, quad

Please note: the information contained in this document is subject to change without further notification. Pyreos reserves the right to alter the performance and any resulting specification. Pyreos may choose not to supply any engineering sample devices as a commercial product. No responsibility is accepted for any consequential loss incurred. LRM- LMM- Pyreos Ltd, 14-16 The Curve, 32 Research Avenue North, Heriot Watt Research Park, Edinburgh EH14 4AP, UK. Tel: +44 131 322 0732, [www.pyreos.com](http://www.pyreos.com) Copyright Pyreos Ltd 2020

## Filters Available

Pyreos has a range of standard products available.

Part number (replaces)	Channel 1 CWL $\mu\text{m}$ / (HPB nm)	Channel 2 CWL $\mu\text{m}$ / (HPB nm)	Channel 3 CWL $\mu\text{m}$ / (HPB nm)	Channel 4 CWL $\mu\text{m}$ / (HPB nm)	Use
<b>PY2706</b> ES2706 (PY0235)	4.26 / (180)	4.64 / (90)	3.30 / (160)	3.91 / (90)	Exhaust, environmental
<b>PY2711</b> ES2711 (PY2213)	3.90 / (200)	3.90 / (200)	4.26 / (180)	8.42 / (180)	Anaesthetic multi-gas detection
<b>PY2710</b> ES2710 (PY2435)	8.75 / (220)	9.65 / (220)	12.23 / (210)	8.55 / (180)	Anaesthetic multi-gas detection
<b>PY2742</b> ES2742	8.42 / (180)	8.55 / (180)	8.75 / (220)	9.65 / (220)	Anaesthetic multi-gas detection
<b>PY2761</b> ES2761 (PY2628)	6.46 / (130)	9.61 / (150)	5.60 / (80)	5.73 / (80)	Food, milk analysis

Note: In some implementations it may be necessary to add an optical high wavelength blocking filter externally to the sensor package.

**Filters Available - continued**

The following filters can be configured upon request. Please inquire regarding other filter requirements.

<b>CWL <math>\mu\text{m}</math> / (HPB nm)</b>	<b>Use</b>	<b>CWL <math>\mu\text{m}</math> / (HPB nm)</b>	<b>Use</b>
2.55 / (90)		5.6 / (80)	Milk, Reference
2.9 / (300)		5.73 / (80)	Milk, Fat
3.3 / (160)	CH <sub>4</sub>	6.2 / (200)	NO <sub>2</sub>
3.33 / (160)	H-C	6.46 / (130)	Milk, Protein
3.38 / (190)	H-C	6.7 / (120)	Milk, Reference
3.7 / (110)	Reference	7.3 / (200)	SO <sub>2</sub>
3.9 / (200)	N <sub>2</sub> O	8.01 / (440)	
3.91 / (90)	Reference	8.42 / (180)	Refrigerants, Anaesthetics
4.26 / (180)	CO <sub>2</sub>	8.55 / (180)	Anaesthetics
4.43 / (60)	CO <sub>2</sub> (Special)	8.75 / (220)	Anaesthetics
4.64 / (90)	CO	9.5 / (400)	Sugar, Ethanol
4.64 / (180)	CO (Narrow)	9.61 / (150)	Milk, Lactose, Sugar
4.85 / (90)		9.65 / (220)	Anaesthetics
4.9 / (130)	Reference	10.27 / (210)	
5.3 / (180)	NO	12.23 / (210)	Anaesthetics